



ROLLER TECHNOLOGY, PRINTING CYLINDER, BRIDGE ADAPTER, WEB TENSION MEASUREMENT

**PRECISION FOR  
MAXIMUM QUALITY STANDARDS**

# INNOVATION FOR OPTIMIZED PRODUCTION PROCESSES

With more than 25 years experience in developing, manufacturing and sales of precision rollers, INOMETA has proven to be a competent, innovative partner for many industrial sectors which have highest demands towards production results or printing processes.

As an innovative company steeped in tradition, we offer solutions that are tailored to your processes. We complement our proven, yet always future-oriented product families with their comprehensive range of standard components with customized products that we manufacture for specific applications according to specifications.

## THIS BROCHURE PROVIDES INFORMATION ON THE FOLLOWING SUBJECTS:

<b>INOMETA</b> .....	4
<b>Aluminium Web Guide Rollers</b> .....	6
Web Guide Roller with Dead Shaft .....	10
Web Guide Roller with Stub Shafts .....	11
Web Guide Roller with Journals .....	12
Customized Metal Rollers .....	13
<b>Sensor Rollers and Web Tension Measuring Technology</b> .....	14
<b>CFRP Rollers and Cylinders</b> .....	16
CFRP Web Guide Rollers .....	20
CFRP Web Guide Roller with Dead Shaft .....	21
CFRP Web Guide Roller Stub Shafts .....	22
CFRP Web Guide Roller Journals .....	23
CFRP Offset Roller Cores .....	24
CFRP Lay-On Rollers .....	26
CFRP High-Q-Rollers .....	28
CFRP Rollers with Surface Structure .....	29
CFRP Bubble-Collapsing Rollers .....	30

# STABILITY AND PROFITABILITY IN ALL PRODUCTION PROCESSES

INOMETA offers complete products from a single source. INOMETA rollers, printing cylinders and bridge adapters are in use wherever web materials are produced, wrapped, cut, printed or processed. All products made by INOMETA are specifically designed and manufactured for their diverse applications. Therefore, their distinguishing characteristics are absolute precision, optimized technical design and perfectly customized surfaces. Innovative solutions in the web tensile force measurement technology which lead to a further increase in profitability in all production and processing activities round out INOMETA's product range.



Innovative product quality based on modern production methods and comprehensive consultation are trademarks of INOMETA.



Expert advice and thoughtful planning are hallmarks of INOMETA.

## Interdisciplinary Competence for Complete Rollers

INOMETA develops and manufactures high-quality web guide rollers as well as precise printing-unit rollers and cylinders made of aluminium and CFRP. Our products meet highest requirements with regard to smooth running and lightweight design, as well as stability and damping. From design and production down to providing functional surfaces, INOMETA provides support for every roller type with interdisciplinary competence.

## Experienced Project Management

With their know-how and experience, our experts offer reliable and secure support in all process-specific questions. For each respective application, they help select perfectly matching INOMETA rollers and cylinders.

Our experienced project managers provide support for the development and production of each product from the quotation phase through to delivery. In the process, they ensure functionality and quality.

## Specific Production Methods with Assured Quality

We have high-performance machinery and use specific production methods. This allows us to offer our customers a wide range of products with many fields of applications. We use ultramodern CNC lathes and automatic lathes as well as grinding and finishing machines to produce our products. We achieve the quality of our products with precise methods and defined manufacturing process cycles.

## About the Company

INOMETA is part of the AVANCO Group, a market leader in the development, production and distribution of web guiding, sensor and functional rollers, shafts and adapters, technical tubes, functional surfaces, and technical winding cores. Our main focus is lightweight design, using aluminium and carbon fiber composite materials to increase productivity and the associated added value.

Our company is certified acc. to the ISO 9001 quality management system. Independent experts regularly review our processes according to strict quality criteria. This ensures the high quality of our products.

PRECISE, SAFE, ECONOMICAL

## ALUMINIUM WEB GUIDE ROLLERS

Made of aluminium, INOMETA's web guide rollers have been tried and tested. Their state-of-the-art design which makes for smooth running guarantees a high degree of productivity and technical safety. We have a modular production system with pre-produced components. In this way, we ensure competitiveness and short delivery times. Our wide range of web guide rollers stands for comprehensive, application-oriented solutions.



The three basic types BA, BB and BC provide a multitude of standard diameter series. In addition, it goes without saying that we will provide you with any other diameter size needed.



Our modular system for aluminium web guide rollers makes it possible to deploy tried and tested technology while reducing the expenditure for development and design.

### Type and Specification Key

Our type and specification key is designed to facilitate communication between INOMETA and its customers. Rollers can be precisely defined without drawings.

	TYPE	D	L	a	A	BEARING	D	G
example	BA	120	01750	050	01850	6204	20	12
tube material	aluminium							

roller with bearings inside	TYPE	BA						
diameter 120 mm	D	120						
tube outer breadth TOB 1,750 mm	L	1,750						
journal length 50 mm	a	50						
overall length	A	1,850						
low friction bearings	DIN	6204						
journal diameter 20 mm	D	20						
fastening thread M12	G	12						

	TYPE	D	L	a	A	BEARING	D	G
the same roller, only hard anodised	BA	120	01750	050	01850	6204	20	12
	aluminium, hard anodised							

## GENERAL TECHNICAL DATA

MATERIALS		
standard	roller tube	AlMgSi 0.5
	base	AlCuMgPb
	shaft / journal	C45
	housing	C45
alternative	optional materials, e. g. stainless steel or CFRP	



BEARINGS	
standard	Conventional fixed and a floating bearing assembly with contact-free labyrinth seal. Low friction bearings with special high viscosity lubricant, bearing clearance and permanent lubrication for heavy-duty use through speed and temperature up to 120 °C
alternative	customer-specific bearing and lubrication systems



TOLERANCES			
standard	roller length	L	h13
	overall length	A	h8
	journal diameter	d	h8
	concentricity	for L > 1,000	< 35 µm/m
		for L ≤ 1,000	< 35 µm
cylindricity	for L > 1,000	< 35 µm/m	
	for L ≤ 1,000	< 35 µm	
alternative	on request		



BALANCING	
standard	dynamically precision-balanced acc. to DIN ISO 1940 for 300 m/min balance quality G = 2.5 or 6.3
alternative	fine-balanced with balance quality G = 1 or elastic/dynamic balancing (third level)

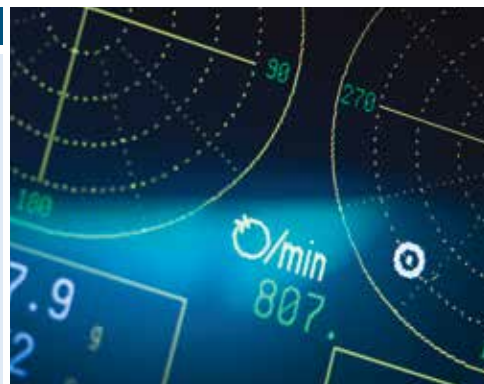

## SURFACE STRUCTURE



STRUCTURE
Surface structures support material guiding; e. g. spiral-groove surfaces have a spreading effect and rhombic-groove surfaces prevent air cushions between material web and roller.

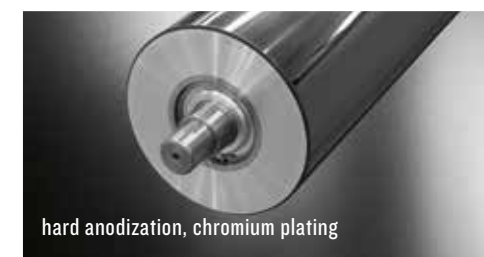

COATING
By choosing the right surface, the characteristics of the roller can be tailored to the specific requirements of your process. With thermally sprayed PROTEK coatings, you can define wear protection, non-stick and/or traction properties. However, hard anodizing, chromium plating or rubber coating are also possible.

SURFACES					
STRUCTURE		ROUGHNESS DEPTH		COATING	
standard	cylindric, polished	standard	aluminium, ground	standard	without coating
alternative	application-oriented, e. g. spiral grooved, grooved, concave/convex, structured		Rz 6–8 µm	alternative	hard anodization, chrome, rubber, PROTEK ceramic coating, PROTEK non-stick coating, PROTEK hard metal coating
		alternative	defined surfaces between Rz .1 µm and Rz 200 µm		

### WEB GUIDE ROLLER WITH DEAD SHAFT TYPE BA

Web guide rollers with dead shaft are manufactured according to INOMETA's modular system. They can be delivered with diameters between 30 mm and 360 mm. Depending on the application, roller lengths of up to 8,000 mm are available.

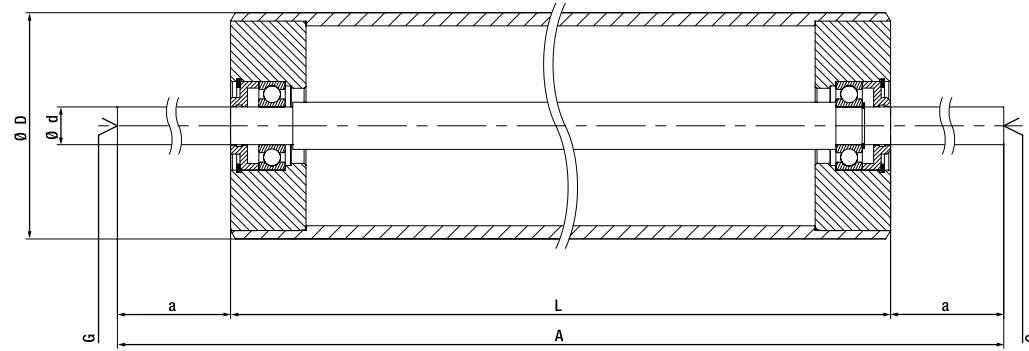

NOMINAL ROLLER DIAMETER	D	60	80	100	120	160	200	250	300		
<b>DIMENSIONS</b>											
tube wall thickness	s	[mm]	5	5	6	7	8	10	10	10	
elasticity modulus aluminium	E	[GPa]	70								
diameter tolerance		[mm]	0.0/-1.0	0.0/-1.0	0.0/-1.0	0.0/-1.0	0.0/-2.5	0.0/-2.5	0.0/-5.0	0.0/-5.0	
tube outer breadth TOB	L	[mm]	optional								
roller upper width, recommended	L <sub>max</sub>	[mm]	1,200	1,800	2,200	2,600	3,800	4,000	6,000	7,000	
journal length	a	[mm]	optional								
overall length	A	[mm]	optional								
bearing	DIN		6004	6204	6204	6204	6204	6206	6206	6206	
journal diameter	d	[mm]	20	20	20	20	20	30	30	30	
fastening thread acc. to DIN 332D	G		M12	M12	M12	M12	M12	M16	M16	M16	
This table offers standard values. The design of the component will take all customer-specific information on dimensions, tolerances and details into account. For available semi-finished tubes, please refer to the Roller Tube Catalog of INOMETA.											
<b>FIGURES RELATING TO MASS</b>											
roller L = 1,000 / A = 1,100	m <sub>G</sub>	[kg]	6.0	7.7	9.7	12.1	17.6	26.7	36	45	
roller, each 1,000 mm	m <sub>L</sub>	[kg]	5.1	6.7	8.2	10.0	13.5	19.6	26	30	
The weight data can change when using alternative semifinished products.											
<b>BALANCING</b>											
balance quality with v = 300 m/min acc. to DIN ISO 1940	G		6.3	6.3	6.3	2.5	2.5	2.5	2.5	2.5	
For aluminium rollers, the balancing speed is limited to the ratio of $v/v_c^* \leq 0.38$ . For a higher ratio, we offer elastic/dynamic balancing. * $v_c \triangleq$ critical speed											

### WEB GUIDE ROLLER WITH STUB SHAFTS TYPE BB

Web guide rollers with stub shafts are produced according to INOMETA's modular system and can be delivered with diameters from 30 mm to more than 360 mm. Depending on the application, roller lengths of up to 8,000 mm are available.

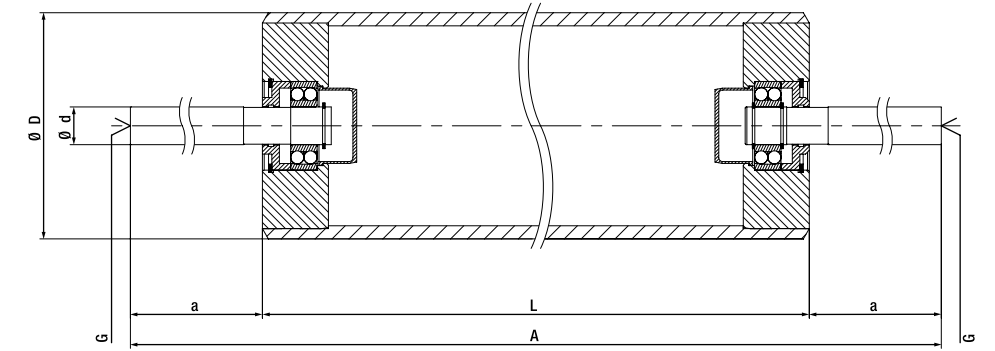

NOMINAL ROLLERS DIAMETER	D	60	80	100	120	160	200	250	300		
<b>DIMENSIONS</b>											
tube wall thickness	s	[mm]	5	5	6	7	8	10	10	10	
elasticity modulus aluminium	E	[GPa]	70								
diameter tolerance		[mm]	0.0/-1.0	0.0/-1.0	0.0/-1.0	0.0/-1.0	0.0/-2.5	0.0/-2.5	0.0/-5.0	0.0/-5.0	
tube outer breadth TOB	L	[mm]	optional								
roller upper width, recommended	L <sub>max</sub>	[mm]	1,200	1,800	2,200	2,600	3,800	4,000	6,000	7,000	
journal length	a	[mm]	optional								
overall length	A	[mm]	optional								
bearing	DIN		1302	1204	1204	1204	1204	1206	1206	1206	
journal diameter	d	[mm]	20	20	20	20	20	30	30	30	
fastening thread acc. to DIN 332D	G		M12	M12	M12	M12	M12	M16	M16	M16	
This table offers standard values. The design of the component will take all customer-specific information on dimensions, tolerances and details into account. For available semi-finished tubes, please refer to the Roller Tube Catalog of INOMETA.											
<b>FIGURES RELATING TO MASS</b>											
roller L = 1,000 / A = 1,100	m <sub>G</sub>	[kg]	3.4	4.1	6.2	8.6	14.1	19.8	28.1	36	
roller per 1,000 mm	m <sub>L</sub>	[kg]	2.1	2.8	4.4	6.2	9.6	12.1	18.4	22.5	
The weight data can change when using alternative semifinished products and bearings.											
<b>BALANCING</b>											
balance quality with v = 300 m/min acc. to DIN ISO 1940	G		6.3	6.3	6.3	2.5	2.5	2.5	2.5	2.5	
For aluminium rollers, the balancing speed is limited to the ratio of $v/v_c^* \leq 0.38$ . For a higher ratio, we offer elastic/dynamic balancing. * $v_c \triangleq$ critical speed											

## WEB GUIDE ROLLER WITH JOURNALS TYPE BC

Web guide rollers with journals are produced according to INOMETA's modular system and can be delivered with diameters from 30 mm to more than 360 mm. Depending on the application, roller lengths of up to 8,000 mm are available.

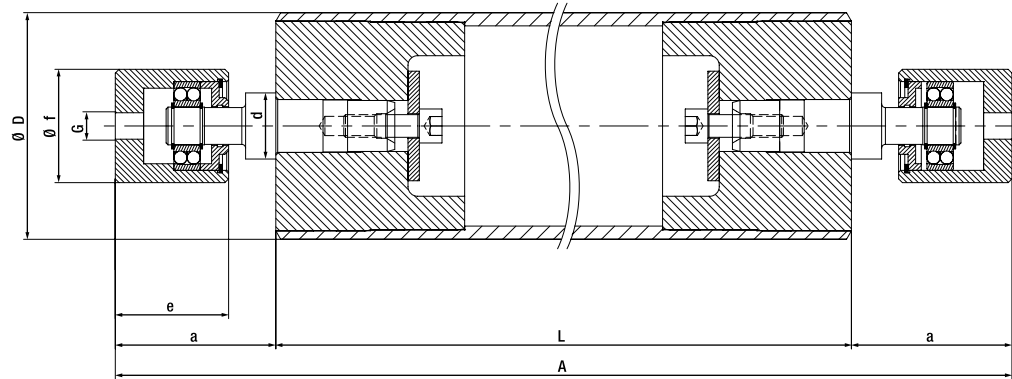

NOMINAL ROLLER DIAMETER	D	60	80	100	120	160	200	250	300		
<b>DIMENSIONS</b>											
tube wall thickness	s	[mm]	5	5	6	7	8	10	10	10	
elasticity modulus aluminium	E	[GPa]	70								
diameter tolerance		[mm]	0.0/-1.0	0.0/-1.0	0.0/-1.0	0.0/-1.0	0.0/-2.5	0.0/-2.5	0.0/-5.0	0.0/-5.0	
tube outer breadth TOB	L	[mm]	optional								
roller upper width, recommended	$L_{max}$	[mm]	1,200	1,800	2,200	2,600	3,800	4,000	6,000	7,000	
journal length	a	[mm]	optional, $a_{min} = e + 10$ mm								
overall length	A	[mm]	optional								
low friction bearings	DIN		1204	1204	1204	1204	1204	1206	1206	1206	
housing length / diameter	e / f	[mm]	60/60	60/60	60/60	60/60	60/60	70/80	70/80	70/80	
journal diameter	d	[mm]	35	35	35	35	35	50	50	50	
fastening thread acc. to DIN 332D	G		M12	M12	M12	M12	M12	M16	M16	M16	
This table offers standard values. The design of the component will take all customer-specific information on dimensions, tolerances and details into account. For available semi-finished tubes, please refer to the Roller Tube Catalog of INOMETA.											
<b>FIGURES RELATING TO MASS</b>											
roller $L = 1,000 / A = 1,100$	$m_G$	[kg]	5.9	7.1	9.5	12.5	20.4	29.1	36	55.9	
roller per 1,000 mm	$m_L$	[kg]	2.1	2.8	4.4	6.2	9.6	12.1	18.4	22.5	
The weight data can change when using alternative semifinished products and bearings.											
<b>BALANCING</b>											
balance quality with $v = 300$ m/min acc. to DIN ISO 1940	G		6.3	6.3	6.3	2.5	2.5	2.5	2.5	2.5	
For aluminium rollers, the balancing speed is limited to the ratio of $v/v_c^* \leq 0.38$ . For a higher ratio, we offer elastic/dynamic balancing. * $v_c \triangleq$ critical speed											

Our qualified team is happy to design modern roller technology for individual tasks and will gladly help with advice.

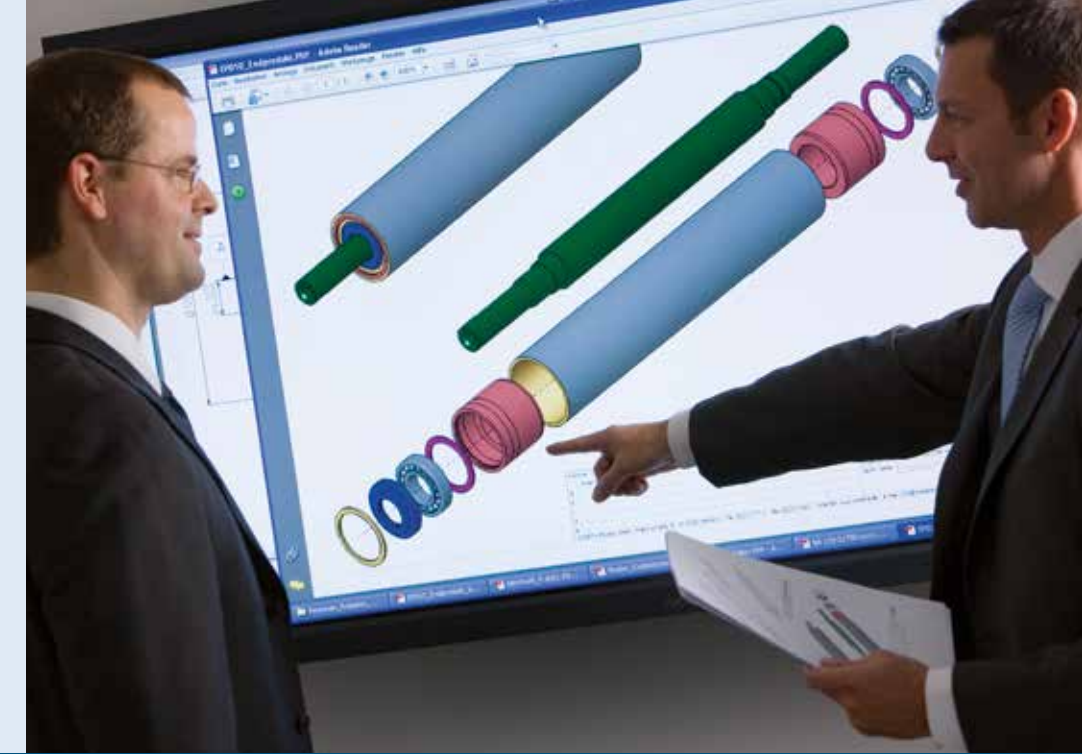

## METAL ROLLERS WITH CUSTOMIZED DESIGN

Our strengths include metal rollers manufactured on an individual basis according to customer specification.

In close consultation with you, we make products according to guidelines determined by the application.

In this case, our product range includes rollers with all common diameters from 30 mm up to 360 mm.

Depending on the requirement, roller lengths of up to 8,000 mm are available.

Our product range of rollers with individually manufactured diameters includes:

- drive and draw rollers
- heating and cooling rollers
- cantilevered rollers, i. e. rollers affixed on one side
- roller bodies

We would of course be delighted to discuss the details of our customer-specific rollers with you in person.

DETECTING PROBLEMS QUICKLY AND CONTROLLING PROCESSES EFFECTIVELY

# INOMETA SENSOR ROLLERS WITH WEB TENSION MEASURING TECHNOLOGY

In recent years, the speed with which materials are printed, coated, wrapped and cut has increased many times over. At the same time, processes are becoming more sensitive and thus more prone to errors. Therefore, precise web guiding is of essence. For one, web guiding enhances the quality of the final product. But it also increases faultless production process runtime.

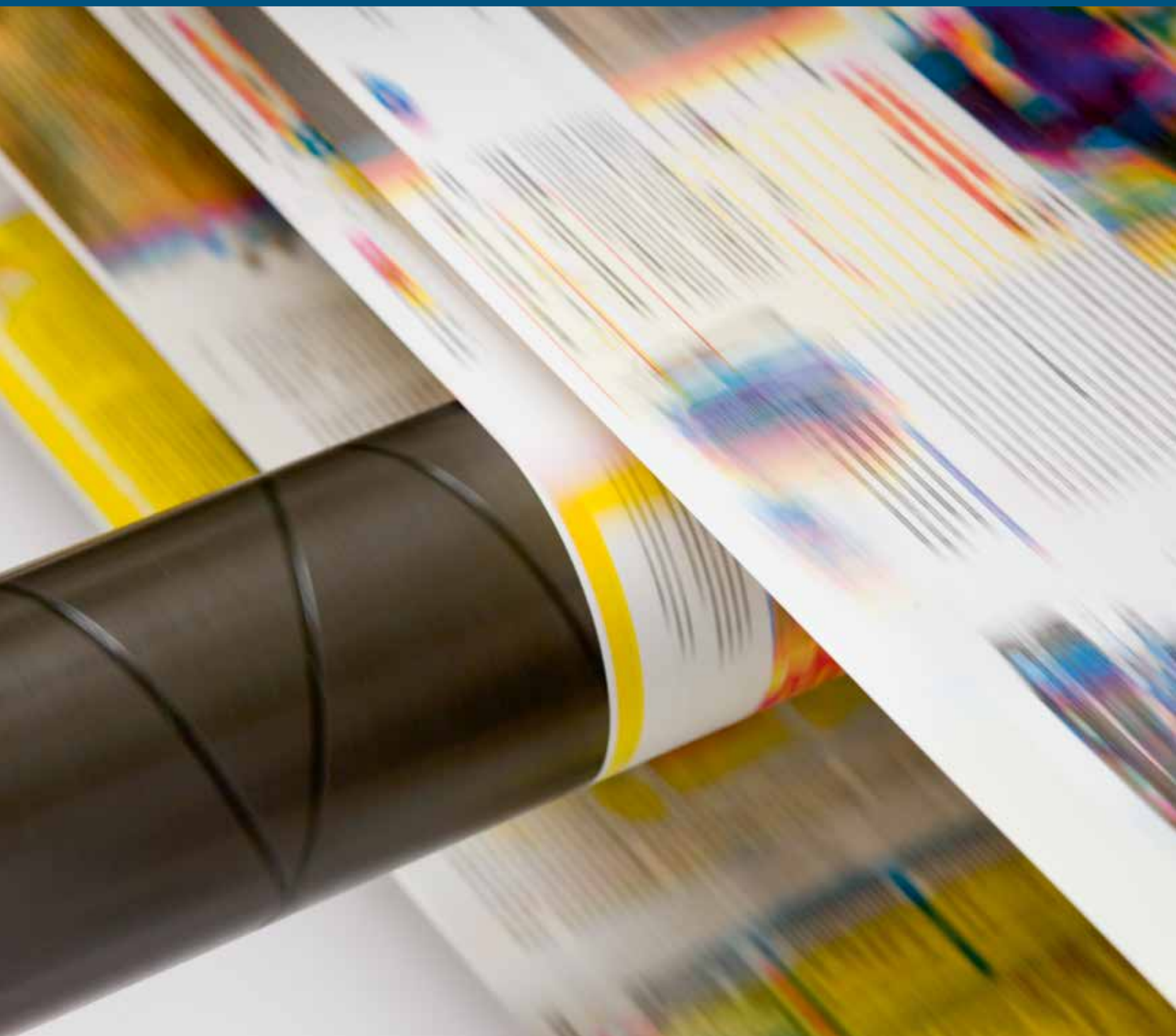

## GUIDING, MEASURING, STEERING

INOMETA sensor rollers with integrated web tensile force measuring unit and amplifier technology not only provide smooth web transport and web tensions with setpoint precision. In addition, they help discover machine-related problems early on, keeping downtimes at a minimum. It combines previously unachieved data logging precision with high-quality roller technology. Made of steel, aluminium or CFRP, this roller is available in individual dimensions and with every common structure and surface refinement.



### SENSOR ROLLERS

Sensor rollers with integrated web tension measuring technology are designed to be ready-to-install while offering precision and durability.

accuracy class 0.2 %  
measurement ranges 0 .. 100 N up to 0 .. 10,000 N

### WTS SENSORS

The WTS sensors are robust classics of web tension measuring technology which are available for many applications.

measurement ranges 0 .. 100 N up to 0 .. 10,000 N



### MEASUREMENT DATA LOGGING AND PROCESSING

in realtime using PC-based software tools.

HIGH-PERFORMANCE COMPOSITE MATERIALS FOR INCREASING DEMANDS

## CFRP ROLLERS AND CYLINDERS

Continuously increasing machine speeds and film web widths are requirements which can hardly be met using conventional rollers made of steel and aluminium. INOMETA rollers are made of CFRP, a modern, state-of-the-art designer material which can meet even especially demanding requirements. CFRP offers a rigidity-weight-ratio which is much higher than that of aluminium or steel. For rotating bodies, this means higher critical speeds with less deflection and mass moment of inertia.

In many of today's applications, CFRP helps us overcome barriers that kept us in place when using conventional materials. As your partner for CFRP rollers and cylinders, we offer interdisciplinary competence from tube design to surface refinement.

### FILAMENT WINDING, PRECISION AS BASIS

Dynamic characteristics are among the most important quality features of any CFRP tube. This is where filament winding makes a unique contribution. This manufacturing process leads to an excellent uniformity of tube which additionally enhances its rotation behavior. Narrow tolerances on shape and position ensure maximum running smoothness for all processes. Our CFRP roller tubes are exclusively made to measure for their respective applications. The advantages of filament winding for specific applications are convincing.



During the filament winding process, the tube is wound onto a high-precision core. By carefully curing the laminate, we ensure that the tube has high thermal and chemical resistance properties, while remaining tension-free. The result is a component with a minimum amount of unbalance which meets the highest requirements with regard to roundness and straightness.

The layer stack-up of each tube is individually optimized. Here, the most important adjusting screws are fiber type, layer thickness and winding angle. In this way, we create a tube that is tailored to the particular application – in terms of rigidity, strength, weight and/or mass moment of inertia, thermal expansion and vibration damping.

Despite this individuality, filament winding is a very productive method of manufacture, as it allows the production of components in one step directly from its raw materials. The high level of flexibility ensures standardized methods and a high degree of process automation.

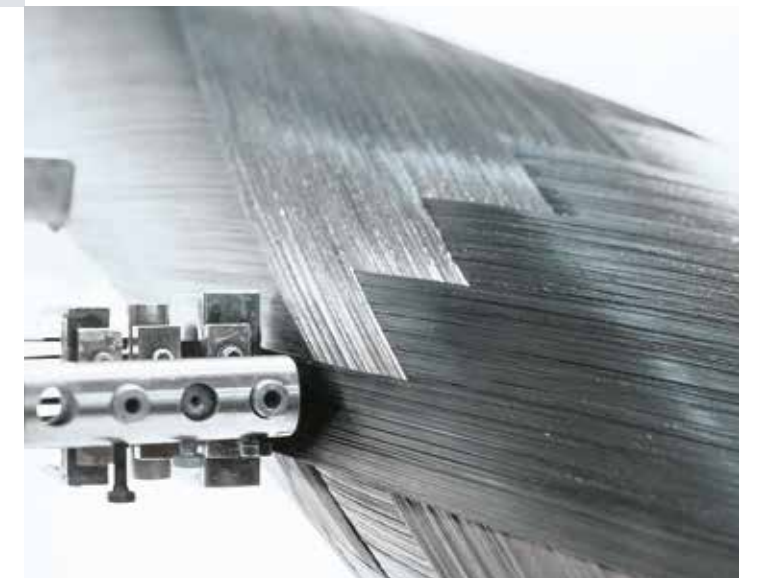



INOMETA is dedicated to continuous product and process innovation so that our customers can maintain their technological and economic edge.

## SPECIAL COATING METHODS FOR COMPLEX REQUIREMENTS

Surface finishing is another key to success for CFRP rollers. For example, high film production operating speeds can cause so-called airplaning effects, which means that an air cushion lets the film float over the rollers. Because of the airplaning effect, the film can no longer accelerate the roller so that it slows down and in turn makes for unwanted relative motions between roller surface and film. When roller and film come back together, the uncontrolled web guiding motion causes either scratches or wrinkles, but ultimately waste. Thermally sprayed functional surfaces made of carbide or ceramics have defined surface structures and/or roughness depths which help prevent the airplaning effect. In addition, integrated polymer particles enhance the transport properties of the surface.

Applying surface coatings on CFRP rollers is much more complex than when working with rollers made of metallic materials. However, INOMETA has mastered a score of highly demanding processes with which the requirements of a wide range of applications can be met.

**Among the tried and tested types of coating we apply are:**

- thermal coatings made of carbide or ceramics
- metallic alloys
- elastomer coatings
- plastic coatings

With these techniques, we ensure that the particular application in which they are used benefits from the highest functionality.

### HIGHLY FUNCTIONAL SURFACE COATINGS

#### PROTEK COMPOSITE COATING

PROTEK composite coatings are processing coatings for mass- and weight-optimized high-performance rollers made of CFRP. They ensure lasting wear protection for web guide rollers in the paper and film production.

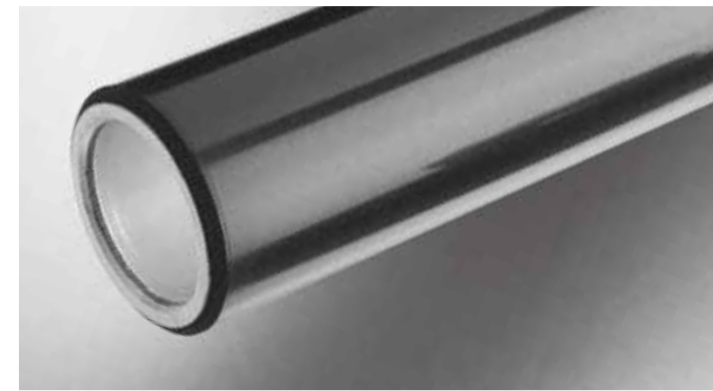
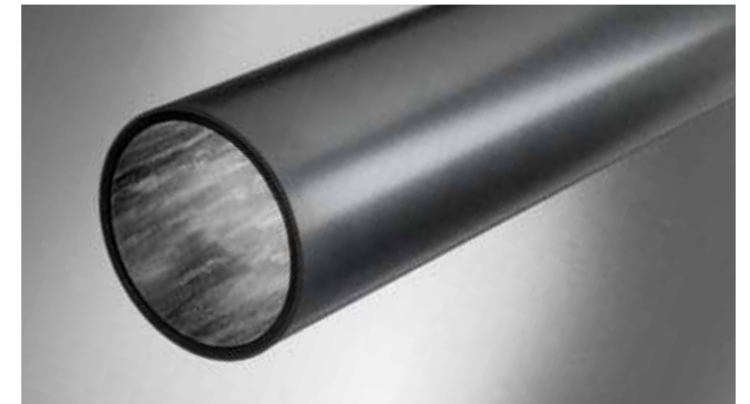

#### PROTEK CERAMIC COATINGS

Ceramic coatings are used primarily as wear protective coating for applications with abrasive materials. Highly purified, they can also be used as base layers for anilox rollers in the flexographic printing industry. They are applied to paper and film guide rollers.

#### PROTEK NON-STICK COATINGS

Non-stick coatings are layers of metal or carbide with polymer seal. They are installed on e. g. web drawing and web guide rollers used for producing or finishing self-adhesive products, films or paper, in the printing and in the hygiene industry.

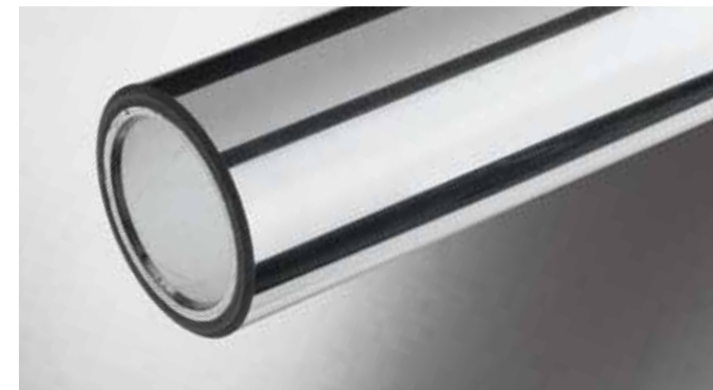
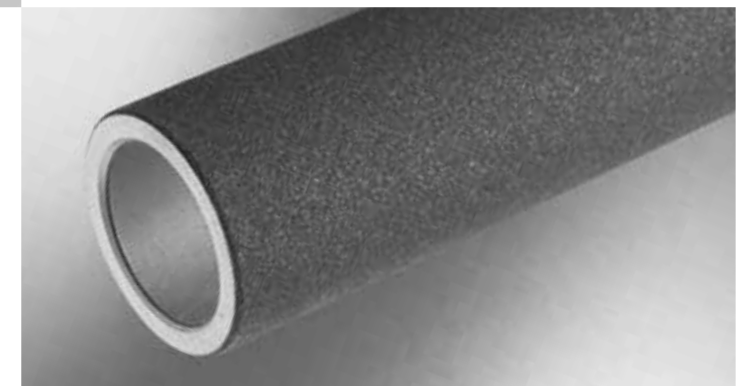

#### PROTEK HARD METAL COATINGS

As carbide-based coatings are extremely wear and cut resistant, they are primarily used on film guide and supporting rollers, cutting tools, paper guiding rollers and calender rollers. With our optimized process technology, we can apply these high-performance coatings to CFRP materials.

LESS WEIGHT FOR MORE SPEED

## CFRP WEB GUIDE ROLLERS

We make CFRP web guide rollers precisely according to customer requirements. They are designed and tailored by our specialists for the relevant case of application. For production, different fiber materials, resins and winding cores are available. After deliberation and consultation with the client, we can select appropriate components which will ensure that in later use the CFRP web guide roller will accurately fulfill the requirements for which it was prepared.

As with aluminium standard rollers, which we offer in three basic types BA, BB and BC, we also offer CFRP rollers in these three basic types. With this modern material, we produce both rollers in the usual dimensions as in various other intermediate dimensions.

### CFRP WEB GUIDE ROLLER WITH DEAD SHAFT TYPE BA

CFRP web guide rollers with dead shaft can be delivered with diameters between 30 mm and 1,200 mm and more. Depending on the application, roller lengths of up to 13,000 mm are available.

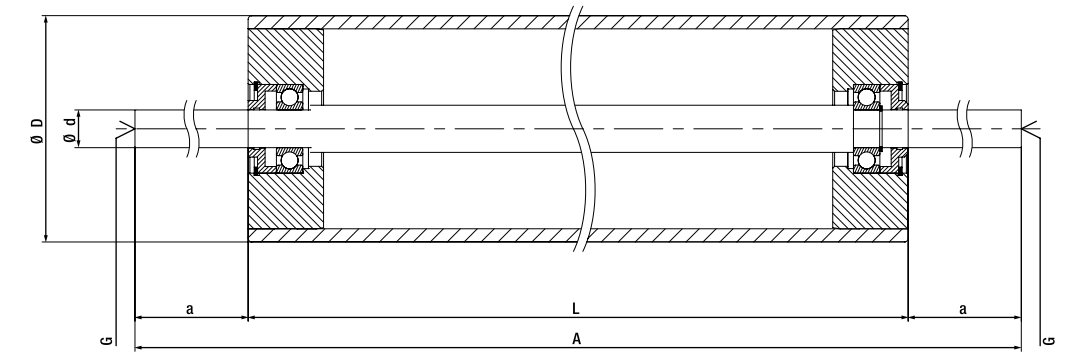

NOMINAL ROLLER DIAMETER	D	60	80	100	120	160	200	250	300	
<b>DIMENSIONS</b>										
tube wall thickness	s	[mm] customer-specific, depending on the application								
elasticity modulus CFRP	E	[GPa] customer-specific, depending on the application, from 110 to 300								
diameter tolerance		[mm]	+/- 0.5	+1.0/0.0	+1.0/0.0	+1.0/0.0	+1.0/0.0	+1.0/0.0	+1.0/0.0	
tube outer breadth TOB	L	[mm] optional								
roller upper width, recommended	L <sub>max</sub>	[mm]	1,200	1,800	2,200	2,600	3,800	4,000	6,000	7,000
journal length	a	[mm] optional								
overall length	A	[mm] optional								
low friction bearing	DIN	6004	6204	6204	6204	6204	6206	6206	6206	
journal diameter	d	[mm]	20	20	20	20	20	30	30	30
fastening thread acc. to DIN 332D	G	M12	M12	M12	M12	M12	M16	M16	M16	
This data is merely intended to provide guidelines. The design of the component will take all customer-specific information on dimensions, tolerances and details into account.										
<b>FIGURES RELATING TO MASS</b>										
customer-specific, depending on the application										
<b>BALANCING</b>										
balance quality with v = 300 m/min acc. to DIN ISO 1940	G	6.3	6.3	6.3	2.5	2.5	2.5	2.5	2.5	
For CFRP rollers, the balancing speed is limited to the ratio of v/v <sub>c</sub> * ≤ 0.4. For a higher ratio, we offer elastic/dynamic balancing. *v <sub>c</sub> ≙ critical speed										

### CFRP WEB GUIDE ROLLER WITH STUB SHAFTS TYPE BB

CFRP web guide rollers with stub shafts can be delivered with diameters from 30 mm up to 1,200 mm. Depending on the application, roller lengths of up to 13,000 mm are available.

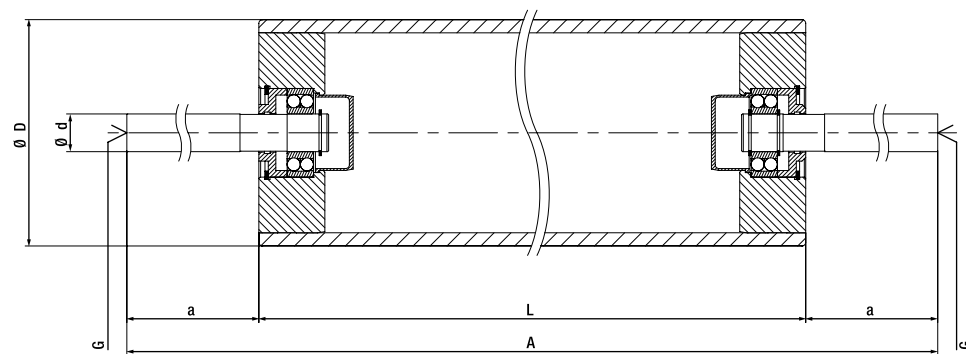

NOMINAL ROLLER DIAMETER	D	60	80	100	120	160	200	250	300
-------------------------	---	----	----	-----	-----	-----	-----	-----	-----

DIMENSIONS									
tube wall thickness	s	[mm]	customer-specific, depending on the application						
elasticity modulus CFRP	E	[GPa]	customer-specific, depending on the application, from 110 to 300						
diameter tolerance		[mm]	+/- 0.5	+1.0/0.0	+1.0/0.0	+1.0/0.0	+1.0/0.0	+1.0/0.0	+1.0/0.0
tube outer breadth TOB	L	[mm]	optional						
roller upper width, recommended	L <sub>max</sub>	[mm]	1,200	1,800	2,200	2,600	3,800	4,000	6,000
journal length	a	[mm]	optional						
overall length	A	[mm]	optional						
low friction bearing	DIN		1302	1204	1204	1204	1204	1206	1206
journal diameter	d	[mm]	20	20	20	20	20	30	30
fastening thread acc. to DIN 332D	G		M12	M12	M12	M12	M12	M16	M16

This data is merely intended to provide guidelines. The design of the component will take all customer-specific information on dimensions, tolerances and details into account.

#### FIGURES RELATING TO MASS

customer-specific, depending on the application

#### BALANCING

balance quality with v = 300 m/min acc. to DIN ISO 1940	G	6.3	6.3	6.3	2.5	2.5	2.5	2.5	2.5
---	---	-----	-----	-----	-----	-----	-----	-----	-----

For CFRP rollers, the balancing speed is limited to the ratio of  $v/v_c^* \leq 0.4$ . For a higher ratio, we offer elastic/dynamic balancing.  
\* $v_c \triangleq$  critical speed

### CFRP WEB GUIDE ROLLER WITH JOURNALS TYPE BC

CFRP web guide rollers with journals are produced according to INOMETA's modular system and can be delivered with diameters from 30 mm to more than 1,200 mm. Depending on the application, roller lengths of up to 13,000 mm are available.

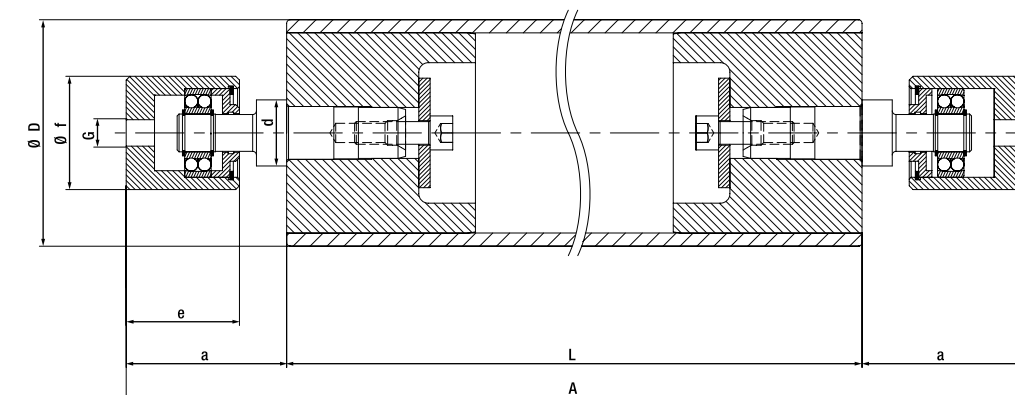

NOMINAL ROLLER DIAMETER	D	60	80	100	120	160	200	250	300
-------------------------	---	----	----	-----	-----	-----	-----	-----	-----

DIMENSIONS									
tube wall thickness	s	[mm]	customer-specific, depending on the application						
elasticity modulus CFRP	E	[GPa]	customer-specific, depending on the application, from 110 to 300						
diameter tolerance		[mm]	+/- 0.5	+1.0/0.0	+1.0/0.0	+1.0/0.0	+1.0/0.0	+1.0/0.0	+1.0/0.0
tube outer breadth TOB	L	[mm]	optional						
roller upper width, recommended	L <sub>max</sub>	[mm]	1,200	1,800	2,200	2,600	3,800	4,000	6,000
journal length	a	[mm]	optional, a <sub>min</sub> = e + 10 mm						
overall length	A	[mm]	optional						
low friction bearing	DIN		1204	1204	1204	1204	1204	1206	1206
housing length / diameter	e / f	[mm]	60/60	60/60	60/60	60/60	60/60	70/80	70/80
journal diameter	d	[mm]	35	35	35	35	35	50	50
fastening thread acc. to DIN 332D	G		M12	M12	M12	M12	M12	M16	M16

This data is merely intended to provide guidelines. The design of the component will take all customer-specific information on dimensions, tolerances and details into account.

#### FIGURES RELATING TO MASS

customer-specific, depending on the application

#### BALANCING

balance quality with v = 300 m/min acc. to DIN ISO 1940	G	6.3	6.3	6.3	2.5	2.5	2.5	2.5	2.5
---	---	-----	-----	-----	-----	-----	-----	-----	-----

For CFRP rollers, the balancing speed is limited to the ratio of  $v/v_c^* \leq 0.4$ . For a higher ratio, we offer elastic/dynamic balancing.  
\* $v_c \triangleq$  critical speed

OFFSET PRINTING: MATERIAL CHARACTERISTICS INCREASE UPTIME

## CFRP OFFSET ROLLER CORES

Talking about modern offset printing means also talking about CFRP. And yet its extremely light weight is but one of many advantages offered by this material. What's more, individual properties can be tailored to different requirements of rollers in the printing unit and can be selectively combined with one another.

This increases the efficiency in the overall process.



The red layer encloses the high-precision CFRP roller core like a protective cover. When renewing the rubber coating, the red color will be a signal which warns of the bottom layer being reached.



Investments that pay off: If you want to protect the quality of your rollers as long as possible, then you should have them retrofitted with PROTEK 3341 now.

### THE BEST POSSIBLE PROTECTION FOR CFRP ROLLERS: THE PROTEK 3341 COATING

#### Riskless Regumming

The renewal of a rubber coating on color and dampening rollers is a demanding task because the removal of the old layer can easily damage the high-quality CFRP roller core.

The PROTEK 3341 re-rubbing layer will help you steer clear of this risk. An effective protection is built up between roller core and re-rubbing layer. In addition, when renewing the rubber coating, the red color will be a signal warning that the bottom layer has been reached. Which means that it not only increases the safety margin, but it also facilitates renewing the rubber coating considerably.

#### Optimum Surface Properties

Besides the very high tensile and compressive strength, the extreme stability of the PROTEK 3341 layer ensures optimum stability for frequent removal of the rubber coating. Thus, the CFRP roller core can survive countless processes of renewing the rubber coating unharmed. PROTEK 3341 has a smooth and even surface which is antistatic and also temperature resistant up to 160 °C. Thus, it is ideal for vulcanizing new rubber coatings.

You can easily clean the PROTEK 3341 layer with the usual cleaning agents and solvents such as acetone, ethanol or gasoline. All in all, the layer allows for easy handling and highest process stability when re-rubbing.

#### Perfect Dynamic Characteristics

Together with the high specific stiffness of the material and the excellent uniformity of the filament winding technology, the tube, being manufactured on a perfect core, ensures the superior running smoothness of the roller. In addition, INOMETA has developed a technology with which the natural frequency and

the damping can be selectively adjusted to ensure that external excitations will not bring annoying vibrations to the roller.

#### Best Protection for CFRP Rollers

If you want to protect the quality of your rollers today, then you should have a PROTEK 3341 layer applied the next time you renew the rubber coating. It goes without saying that all CFRP rollers manufactured today can be purchased with full protective features. The initial costs quickly pay for themselves, because with PROTEK 3341 you benefit from a prolonged and permanently error-free production uptime.

- doubling the critical speed
- reduced deflection
- lighter than steel rollers by up to 70 %
- easier setup, dismounting, handling
- smooth running thanks to damping properties (factor 5 – 20 compared with steel)

In the offset printing unit: inking roller, ink transfer roller, dampening roller, rider roller, bridge roller and dampening ductor



The even contact of the lay-on roller on the web reel is crucial to the winding quality.

BIAXIAL FOIL: MINIMUM DEFLECTION, MAXIMUM UNIFORMITY

# CFRP LAY-ON ROLLERS

In the production of biaxially stretched films with wide material widths, the lay-on roller is of central importance because this roller is pressed against the winding material as it is being wound up to prevent air from getting between the material webs.

Correct winding is an important parameter for the film production speed. Even with the highest machine speeds, the film reel must be perfectly even. Irregularities in cylindricity, winding hardness or edge shape are not tolerated. This error is mainly caused by air which gets trapped between the layers of winding material.

The lay-on roller is designed to prevent the air entrainment effect. To this end, the lay-on roller presses the winding material against the bale to flatten out air pockets and prevent them from being drawn into the bale. The important thing is that the lay-on roller needs to be flush against the entire working width of the bale. Here, special design CFRP rollers with low deflection rate are used.

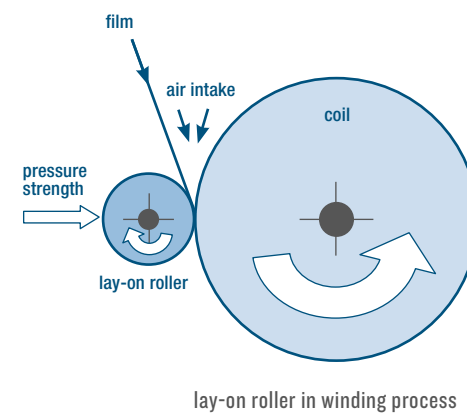

## LDS LAY-ON ROLLERS AS PASSIVE SYSTEM

LDS stands for 'Low Deflection System' and our LDS lay-on rollers made of CFRP have extremely low deflection values. This LDS roller has a body made of CFRP with a specific structure. The concept of this roller body is based on the principle of shifting the load bearing points. In comparison, the maximum deflection of an INOMETA LDS lay-on roller is around 90 % lower than that of traditional lay-on rollers.

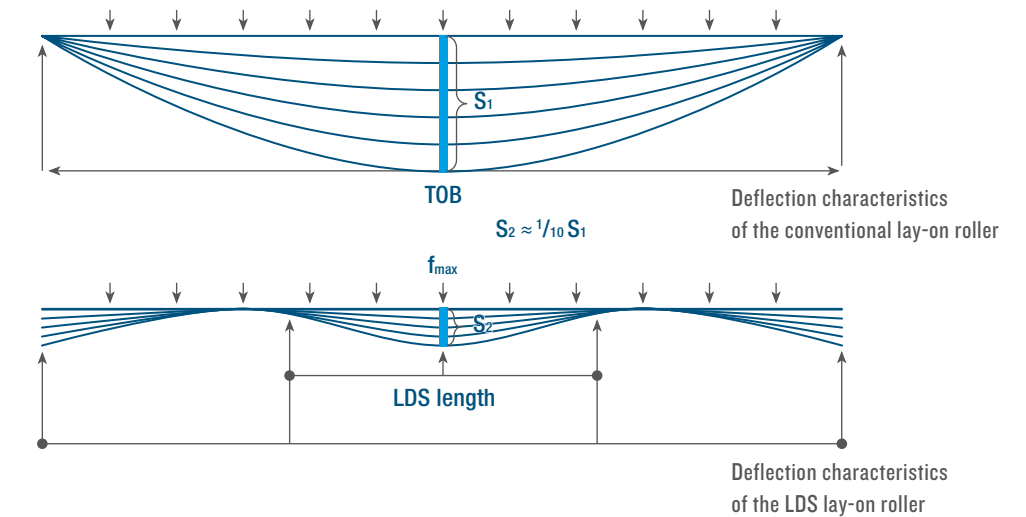

## ALDS LAY-ON ROLLERS AS ACTIVE SYSTEM

The Active Low Deflection System (ALDS) lay-on roller is an active lay-on roller which independently reacts upon various machine parameters. The pressure application line can be continuously adjusted during winding operation. This makes it possible to respond to the different pressure strength characteristics which are required during a wrapping cycle.

For example, the ALDS lay-on roller can be adjusted using a self-sustaining control unit which is tied into the winder control system. Therefore, the signal of the current winding pressure is used to adjust the roller form automatically in defined steps and thus provides optimal contact force between roller and bale.

a change in distribution of pressure strength. This means that the pressure strength can be shifted towards the center or towards the edges of the bale, as needed.

By constantly monitoring the process parameters and the automatic readjustments, the ALDS lay-on roller can react to changing operating conditions. Changes in web tension or in pressure strength can be balanced with

Contact characteristics are adjustable.





High-Q for Gentle Web Guiding

## SCREEN FILM: LEAST ROUGHNESS DEPTHS FOR FLAWLESS PRODUCTION

# CFRP HIGH-Q-ROLLERS

Transparent technical and optical films for television screens or displays set the highest standards of deflection rollers.

For this application, INOMETA has developed the high-performance CFRP High-Q roller. It has a defined chrome or hard-metal surface with very low surface roughness.

An extreme running smoothness, a low mass moment of inertia and a perfect surface quality ensure that a film of the highest quality and free of scratches or scars can be produced.

With these high-performance surfaces, optics and absolute accuracy are crucial for the reliable production of the product. Especially when cleaning rolling surfaces, defects are often caused which bring costly downtime or reject rates with them. When using PROTEK

surfaces, you can apply conventional cleaning methods without destroying the surface.

The very hard surface and a high-precision CFRP core make for a guide roller which meets the highest standards concerning rotation and cylinder form. Because of the intelligent layer structure, it is easily possible to apply a new coating without damaging the core.

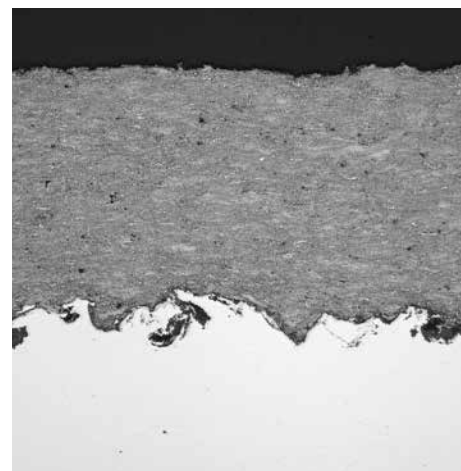

Density and low porosity of the layer are the basis of surface.



Structure Supports Dynamics

## CAST FILM: SYNTHESIS FOR HIGH PRODUCTIVITY AND PERFORMANCE

# CFRP ROLLERS WITH SURFACE STRUCTURE

Stretch film production facilities usually have high production speeds and large working widths. Which means that the performance of these facilities has far-reaching demands with regard to roller technology.

INOMETA's product portfolio has a special roller technology ready for applications like this: a synthesis of surface structure and coating. The dynamic behavior of the roller is individually determined by taking roller diameter, tube wall thickness and a targeted selection of fibers into account. Thanks to a well-balanced combination of surface structures and traction coatings, the airplaning effect, through which an air cushion lifts the film off the rollers, is no longer of concern.



Web Production at Maximum Speed



Bubble-collapsing rollers are designed for smooth running.

## BLOWN-FILM: PRECISE ADAPTATION TO PRODUCTION

# CFRP BUBBLE-COLLAPSING ROLLERS

The production of packaging and food-wrapping films is a highly demanding process.

INOMETA bubble collapsing rollers are perfectly adapted to the specific needs of blown-film production.

The outstanding features of INOMETA's bubble-collapsing rollers are a lightweight design which includes special ball bearings with special smooth-running grease as well as a weight-optimized journal and base structure. These features ensure excellent, smooth operation of the rollers. Development, design and production according to the filament winding process are carried out at INOMETA's own site. We do this to make sure that our customers receive products of the highest product safety standards.



Blown-Film Production





INOMETA GmbH  
Planckstraße 15  
32052 Herford  
Germany

T +49 (5221) 777-0  
F +49 (5221) 777-500  
[info@inometa.de](mailto:info@inometa.de)  
[www.inometa.de](http://www.inometa.de)

#### CONTACT USA

INOMETA INC.  
71 Newtown Rd  
Box 140  
Danbury, CT 06810, USA

T +1 914 602 6572  
[info@inometa.de](mailto:info@inometa.de)  
[www.inometa.de/en](http://www.inometa.de/en)